

Manotizer type 23704



Touchless hand disinfection dispenser

- Quick application of disinfection liquid on both hands at the same time
- Accurate flow of preset quantity
- High performance membrane pump avoids the outflow of surplus liquid
- Less handling by using a 5l reservoir
- Easy to clean
- Completely made of stainless steel 1.4301
- Special circuit board to activate automatic doors

Optional

- Available on pedestal (various types)

Technical data

Type	23704
Measurements (DxWxH)	216x352x851 mm
Main connection voltage	230 V/PE
Nominal rating power	0.05 kW
Mains frequency	50 Hz
Control voltage	24V DC
Protection class	IP44
Net weight	Approx. 11 kg
Room temperature	Min. +4°C, max. +40°C

Technical data may be subject to changes

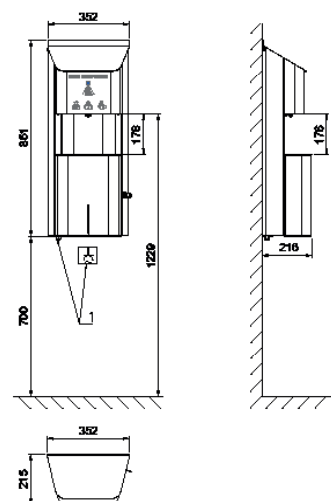

Contact

CN: shanghai@frontmatec.com
Phone: +86 215 859 4850

DK: kolding@frontmatec.com
Phone: +45 763 427 00

NL: rijssen@frontmatec.com
Phone: +31 886 294 000

UK: birmingham@frontmatec.com
Phone: +44 121 313 3564

itec-hygiene.com
frontmatec.com

DE: hygiene@frontmatec.com
Phone: +49 252 185 070

ES: barcelona@frontmatec.com
Phone: +34 932 643 800

RU: moscow@frontmatec.com
Phone: +7 495 424 9559

US: kansascity@frontmatec.com
Phone: +1 816 891 2440